

INSTRUCTION MANUAL



KEPCO An ISO 9001 Company.

**KIT
DIN MRW-150P,
-160P, -170P**

DIN-RAIL MOUNTING KIT FOR SERIES MRW 150/151KV, 160/161KV, 170/171KV

DESCRIPTION. Kepco KITS, Models DIN MRW-150P, MRW-160P and MRW-170P each contain a cover, a cable kit, a mounting bracket with left and right preassembled mounting clips and associated hardware used to install MRW Series power supplies on a DIN rail. The -150P suffix is for the 35 Watt MRW 150/151KV models. The -160P suffix is for the 50 Watt 160/161KV models. The -170P suffix is for the 65 Watt MRW 170/171KV models. The "P" suffix is for mounting the power supply perpendicular to the DIN rail as shown in Figure 1. Outline Dimensions are shown in Figure 5

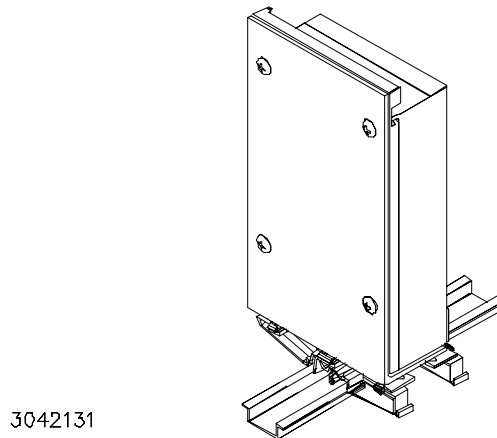

FIGURE 1. P SUFFIX ORIENTATION

TABLE 1. COMPONENTS SUPPLIED

KIT MODEL NO.	CABLE KIT PART NO.	COVER PART NO.	MOUNTING BRACKET PART NO.	SCREW (QTY 4) (Power Supply To Mounting Bracket) PART NO.	WASHER (QTY 4) (Power Supply To Mounting Bracket) PART NO.	CLIP (QTY 2) PART NO.	CLIP PLATE (QTY 2) PART NO.	SCREW Thread-form (QTY 4) (Clip To Mounting Bracket) PART NO.	WASHER (QTY 4) (Clip To Mounting Bracket) PART NO.
DIN MRW-150P	219-0184	CA 19	128-2048	101-0383 (8-32 X 3/16 PHPH)	103-0017 (NO. 8, INT. TOOTH)	108-0362	128-1938	101-0443 (4-40 X 1/4 BPHH)	103-0014 (NO. 4, INT. TOOTH)
DIN MRW-160P	219-0184	CA 20							
DIN MRW-170P	219-0239	CA 20							

KEPCO, INC. ● 131-38 SANFORD AVENUE ● FLUSHING, NY. 11352 U.S.A. ● TEL (718) 461-7000 ● FAX (718) 767-1102
<http://www.kepcopower.com> ● email: hq@kepcopower.com

INSTALLATION

1. **INSTALL COVER.** Attach the cover to the power supply per instruction manual supplied with the cover.
2. **INSTALL MOUNTING BRACKET.** Attach the mounting bracket to the power supply using the hardware supplied (see Figure 2).

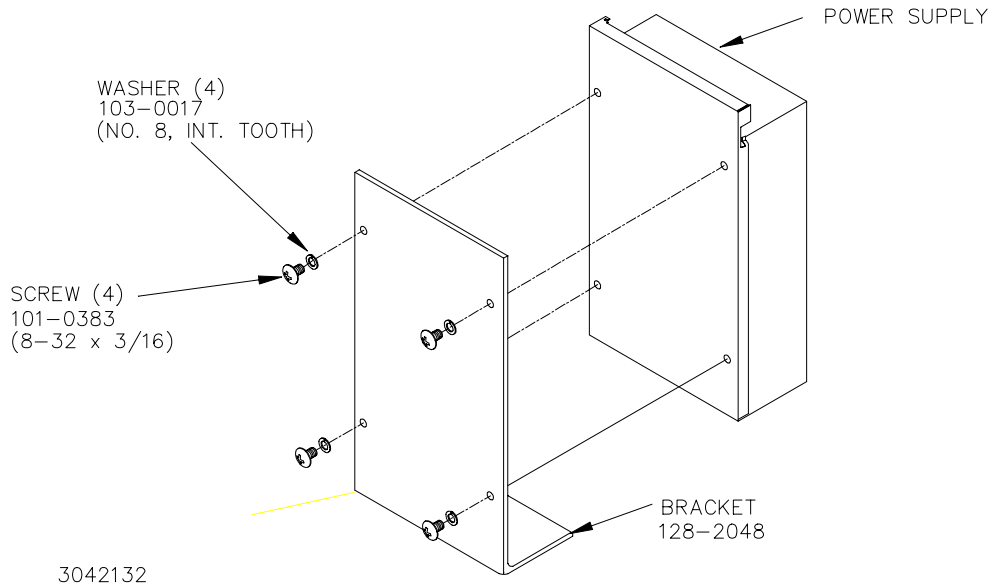

FIGURE 2. INSTALLING MOUNTING BRACKET ON POWER SUPPLY

3. **INSTALL CLIPS.** Attach preassembled mounting clips into the mounting bracket holes using hardware supplied (see Figure 3).

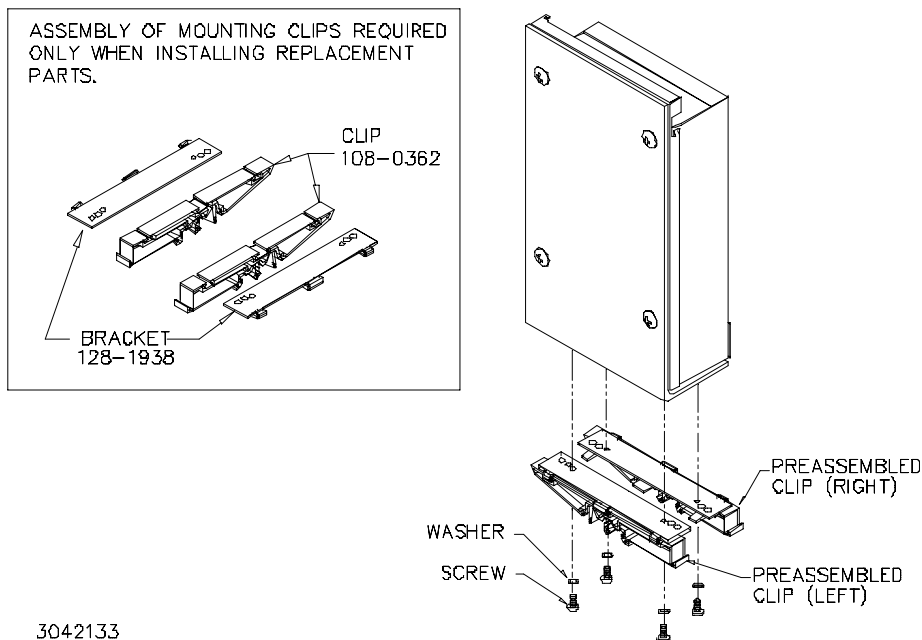
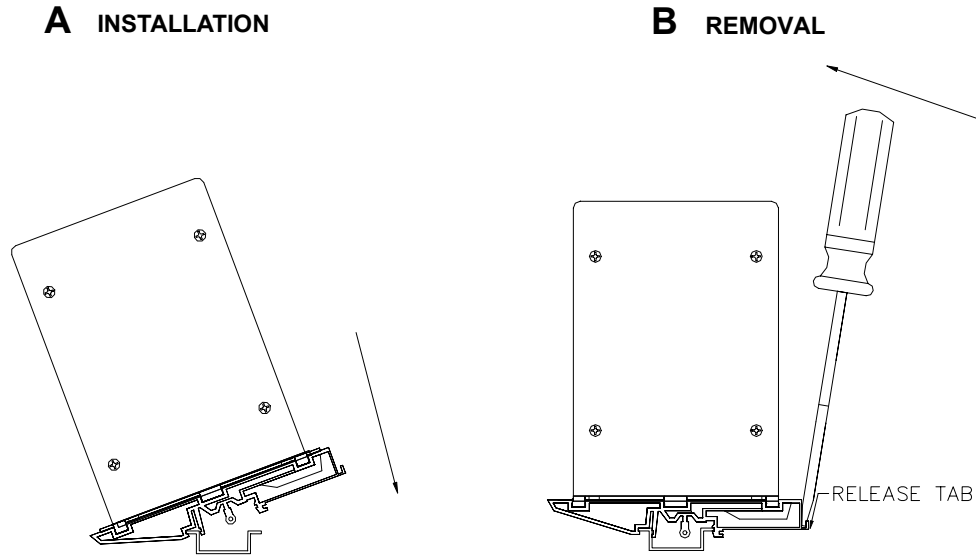

FIGURE 3. INSTALLING CLIPS ON MOUNTING BRACKET

4. **INSTALL CABLE KIT.** Attach wires to the power supply per Instruction Sheet supplied with cable kit.
5. **INSTALL POWER SUPPLY ON DIN RAIL.** To mount the power supply on the rail insert one end of both mounting clips under one edge of the rail, then snap the other end of the two clips into place (see Figure 4A).



3042134

FIGURE 4. INSTALLATION AND REMOVAL OF POWER SUPPLY FROM DIN RAIL

REMOVING POWER SUPPLY FROM DIN RAIL. While grasping the power supply with one hand, Insert a screwdriver into the access holes provided and apply leverage towards the left as shown in Figure 4B to disengage each clip from the rail. Where mounting clips are close together, it may be necessary to apply leverage with two screwdrivers simultaneously.

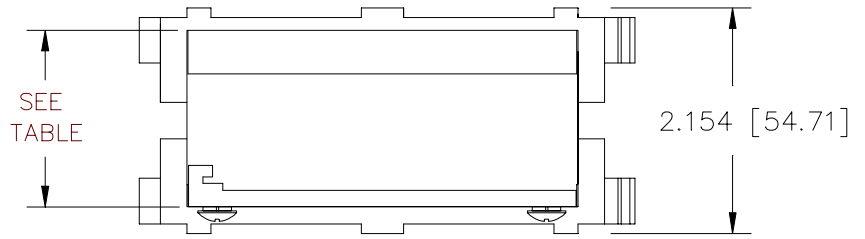

MODEL	DIMENSION
MRW 150KV, 151KV	1.740 [44.20]
MRW 160KV, 161KV	2.060 [52.32]
MRW 170KV, 171KV	2.060 [52.32]

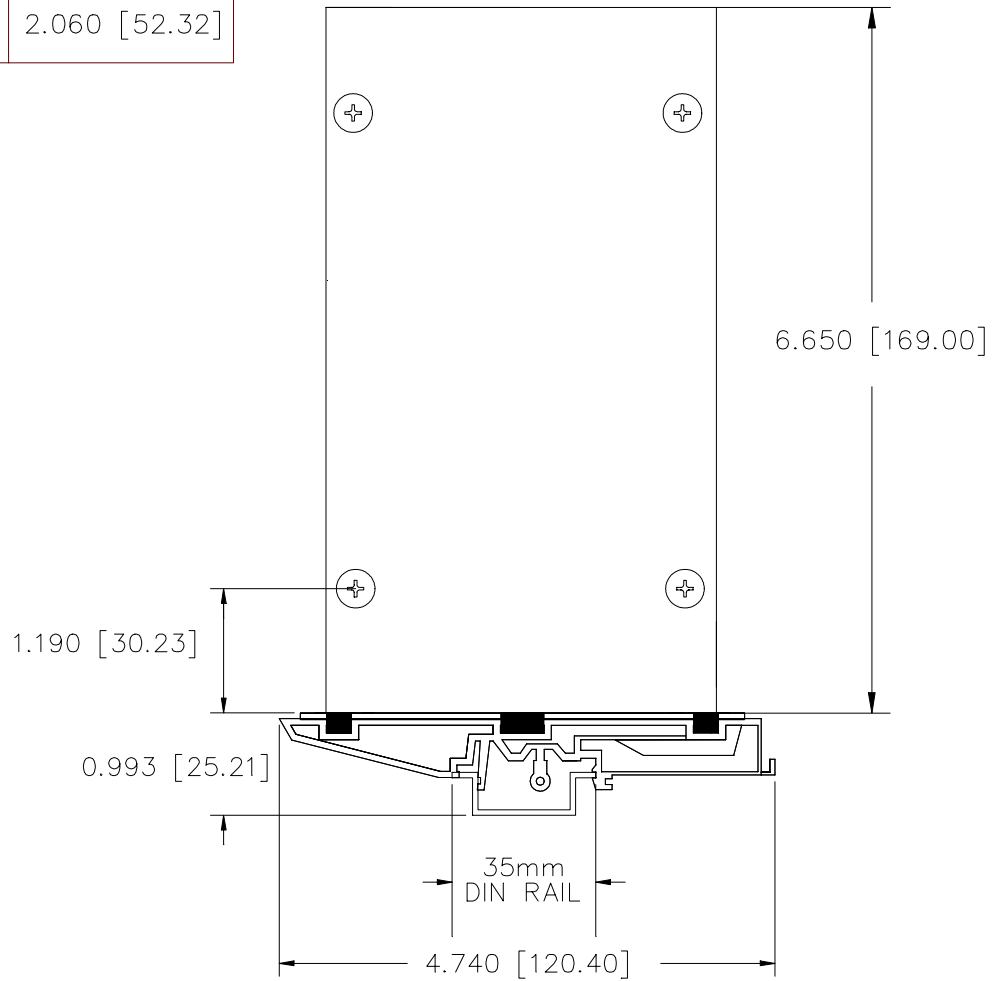

NOTE:

UNLESS OTHERWISE SPECIFIED: DIMENSIONS ARE IN INCHES,
DIMENSIONS IN BRACKETS ARE IN MILLIMETERS.

3042137

FIGURE 5. MRW 35W/50W/65W POWER SUPPLY WITH KIT INSTALLED, OUTLINE DIMENSIONS